

# IntenCity-1™



## Sea Turtle Safe LED Luminaire SL1600amber

### Applications

Solid-state lighting system for:

- coastal, Sea Turtle habitat areas
  - coastal parking lots
  - high vibration bridges & tunnels
  - sub-zero temperatures
  - tropical storm areas
- Replaces 100 watt LPS



### Features

Low EPA (Effective Projected Area) for lowest wind-load of any luminaire. Designed for 120+ MPH winds.

Unique integral Down Looking Photocell, no opening in housing, no wiring, and outlasts LEDs.

Amber LEDs with proprietary optics and control system.

Sealed light engine has no air intake and never needs internal cleaning.

No Ballast. High PF current regulated, solid-state power supply, completely encapsulated for weather resistance. Integral 7KA 180-Joule MOV transient protection.

### Specifications

Lighting System Light Emitting Diodes  
 Input Power 65VA, PF > 0.95  
 Operating Voltage 100 to 277VAC, 47 to 63 Hz.  
 Humidity 0 - 99%  
 Dust and Moisture IP66 rating (no intrusion)  
 Operating Temperature -40° C to 55° C  
 Storage Temperature -40° C to 85° C  
 Finish Black Anodized  
 Dimensions 4 3/8" H x 16" W x 17.5" L  
 Mounting Fits existing 1.5" or 2" pipe  
 Weight 13 lbs  
 Connections 3 x 8" 16 AWG wire leads  
 Photocell ON < 1 footcandle, OFF @ > 1.5  
 Emission Color 590 nm (Amber)  
 Lumens approx. 1,600  
 Compliance to Codes & Standards UL-C, NEC, NEMA, FCC Part 15 Class B  
 General Light weight. Sharp optical cutoff, limited trespass, non-glare, 10+ year design life.  
 Lumen Maintenance 70% after 50,000 hrs. at 30° C ambient temperature



### Installation

Luminaire mounts to standard 1.5" or 2" pipe fitting of streetlight mast or pole, using proprietary single-knob attachment.



### Options

Building and Wall mounting

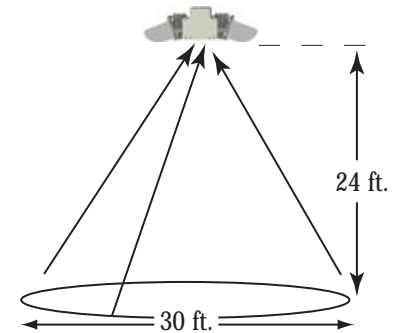

Typical Photocell Detection Area

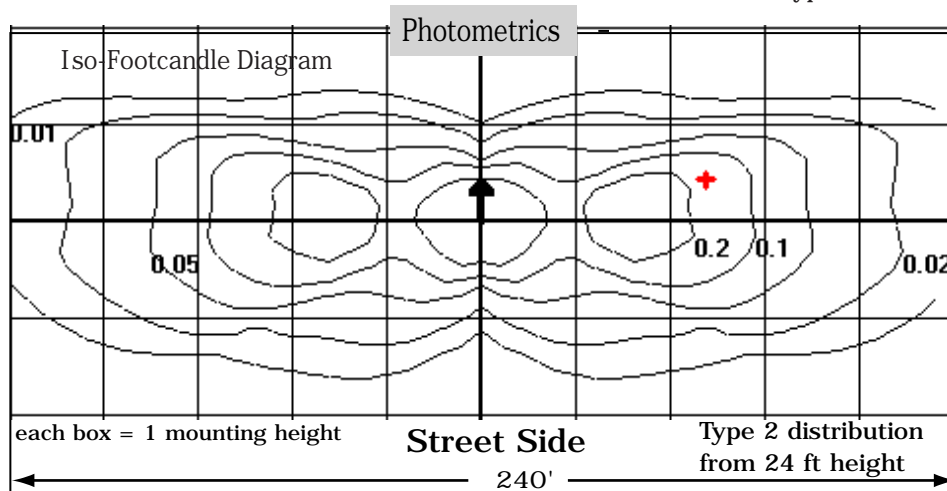

IntenCity Lighting, Inc. P.O. Box 487, Dardanelle, AR 72834 (479) 229-0013

IntenCity-I is a trademark of IntenCity Lighting, Inc. (ILI) All rights reserved. U.S. & International Patent(s) Pending. ILI is not responsible for improper use or application of product. ILI reserves the right to change or improve product specifications without notice.

[www.IntenCityLighting.com](http://www.IntenCityLighting.com)