



Double SL-50 Parking Lot & Street Light

High output LED luminaire for street lighting, parking lots, garage roof decks, and other outdoor uses.



Double SL-50, High Efficiency Solid State Luminaire, Saving 37% to 60% over traditional Metal Halide or High Pressure Sodium Fixtures.

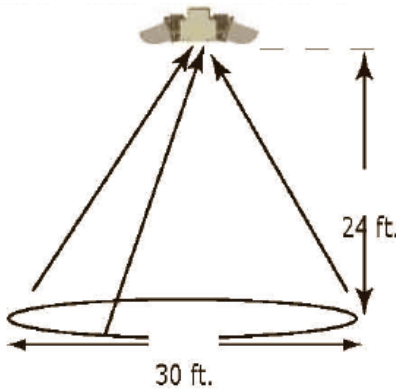

Patented integral down looking photo control, using IR detection to prevent day burning. Photocell requires no openings in the housing, no wiring and is designed for the life of the fixture.

Overview:

The Double SL-50 Street Lighting system is a United States manufactured, high output LED luminaire well suited to street lighting, parking lots, upper roof decks of parking garages, and other outdoor applications where rugged conditions are found. The IntenCity Double SL-50 contains a high efficiency light engine, driver electronics to maximize power utilization, and thermal management to prolong the life of the lighting fixture. The LED luminaire is constructed of high quality materials for low maintenance, vandal resistance and long service life.

Applications:

Typical applications for the Double SL-50 solid state lighting system include:

- Residential and Commercial Streets
- Parking Lots
- High Vibration Areas
- Roof Decks of Parking Garages
- Other places where traditional 150 to 400 watt Metal Halide and High Pressure Sodium lights have been used
- Quick mounting hardware to standard 1.5" or 2" pipe fittings for ease of installation.

Features:

- High output LED light engine delivering 12,000 lumens
- White LED light engine with proprietary directional optics for maximum coverage with low numbers of fixtures.
- Patented thermal management system to prolong LED life, protect the electronics and maintain lumen output over the long life of the fixture.
- High power factor current regulated, solid-state power supply, encapsulated for weather resistance. Integral transient protection.
- Low Effective Projected Area for low wind load on the luminaire. Wind tunnel tested to 150 MPH.
- Sealed light engine with no air intake, requiring no cleaning.

Full LM-79, LM-80 reports and IES files available to aid in engineering and design.

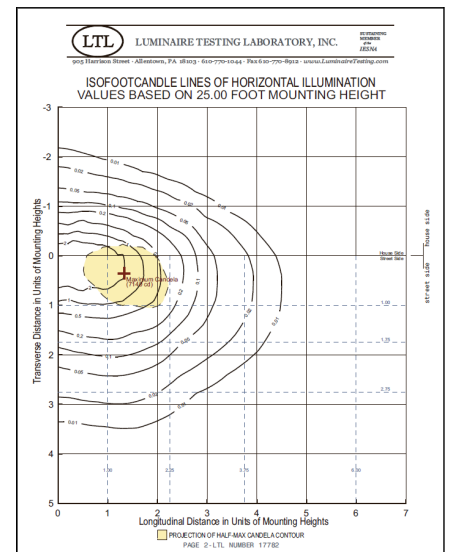

Compatibility Chart / Energy Savings

Traditional Source	Double SL-50	Energy Savings
HPS 400 watts	158 watts	60%
MH 250 watts	158 watts	37%

U.S. and International Patents Issued and Pending.
 US 7,419,128 B1, US 7,569,802 B1,
 US 7,578,605 B1, US 7,806,563 B1

Double SL-50 Parking Lot & Street Light Specifications

Solid-State Outdoor LED Luminaire



The Double SL-50 provides effective lighting in garage applications on the upper deck of the structure.



Made in USA

General Specifications

General	Light-weight fixture, sharp optical cutoff with limited light trespass, non-glare light engine.
Light Output	12,000 Lumens
Durability, Dust, and Moisture	Intrusion Protection Rating – IP66 on light engine, photo controls, and power supply
Color	5,000K Typical, other options available
Photo Control	On < 1 foot candle, Off at > 1.5 foot candle
Lifetime	10+ Year Design Life, over 70% of original lumen output after 70,000 hours at 30°C ambient temperature

Environmental Specifications

Operating Temperature	-40°C to 55°C
Storage Temperature	-40°C to 85°C
Humidity	0% to 99%

Power and Compliance Standards

Input Power	PF > 0.95
Wattage	158 watts
Operating Voltage	100 to 277VAC, 47 to 63 hertz, 480 VAC option avail.
Connections	3 wire: line, neutral and ground

Codes and Standards NEC, NEMA, FCC Part 15 Class B, UL 1598 and 1870

Physical Specifications

Finish and Construction	Clear Anodized Aluminum, and Stainless Steel. Heavy gauge aluminum extrusion, clear anodized finish, stainless steel fasteners, Injected molded, gasket sealed polycarbonate lens. Lower compartment opens for electrical connections and installation.
Dimensions	4 3/8" H x 12 1/2" W x 23" L
Weight	32 Pounds

Ordering Information:

Family	Watts	Voltage	Color Temp.	Distribution	Photo Control	Color	Mount
SLD-50	158 Watts	100 – 277 volts 480 volts Custom: Contact Factory	4,100K 5,000K 6,500K	Type II Type III Type IV	Enabled Disabled	Silver Custom: Contact Factory	Pipe Mount: 1.5" - 2.0" 1.25" - 1.5" Custom: Contact Factory



Contact Information:
 Phone: 1.518.409.8090
 Fax: 1.518.409.8091
 eMail: info@IntenCityLighting.com
 Web: www.IntenCityLighting.com

Efficient, economical, highly engineered light fixtures saving our customer's energy